

NOTE:
1- USE 4043 WELD WIRE.
2- 6063 ASSEMBLY .375 WALL OR LESS TO BE HEAT-TREATED TO T6 TEMPER AFTER WELDING.

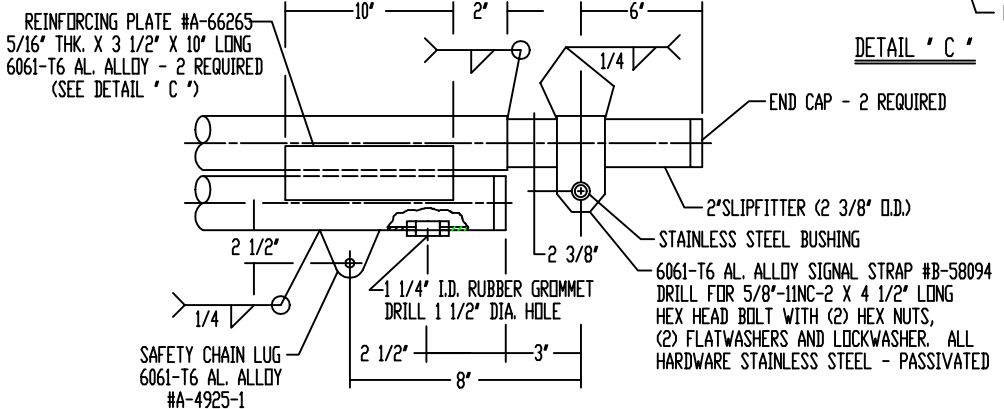
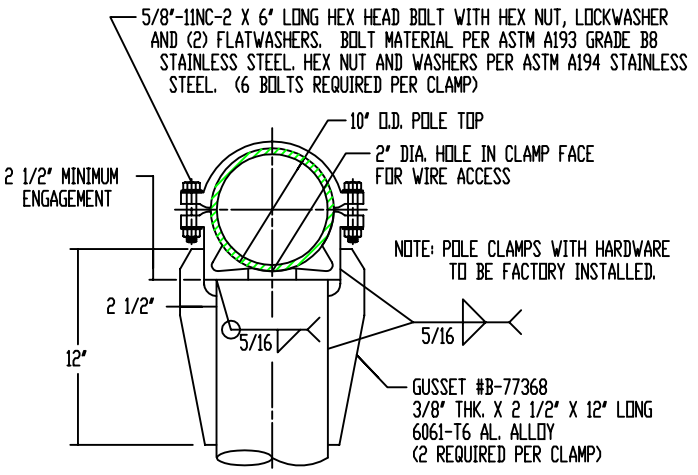
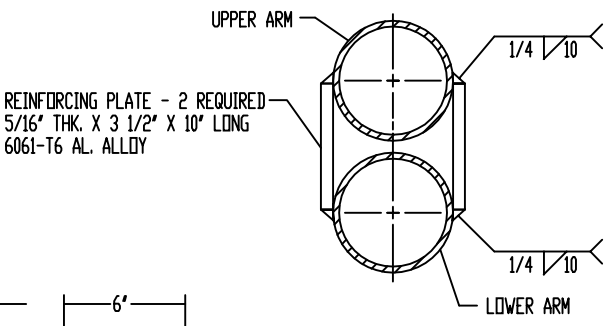

P&K

P&K					P&K POLE PRODUCTS, INC. 84 Foundry St., Newark NJ	
ALL	DESCRIPTION	DATE	BY	CHK	TITLE BERGEN CODE ' MA30-12 ' MA3070810-70	
MATERIAL					DR. M.M.S. 05-19-94 DWG. NO.	
STOCK SIZE					CL. W.W.V. 05-19-94	
FINISH OR TEMPER					APP. SCALE NONE	
CUSTOMER					C-104251	
BERGEN COUNTY DEPT. OF PUBLIC WORKS						